

area ant.

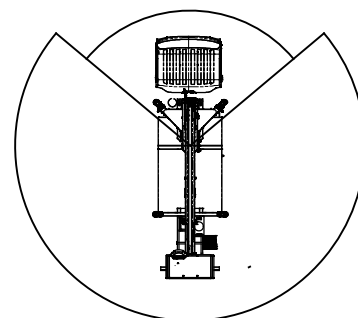

area max
260°

CARATTERISTICHE TECNICHE – TECHNICAL SPECIFICATIONS



ALTEZZA MAX DI LAVORO – MAXIMUM WORKING HEIGHT	17,7m
ALTEZZA PIANO DI CALPESTIO – WALKING FLOOR HEIGHT	15,7m
SBRACCIO MAX DI LAVORO	11m
PORTATA – MAXIMUM CAPACITY LOAD	300kg

DIS. _____ APPROV. _____

PIATTAFORMA
AERIAL WORKING
PLATFORM

18T area nissan

H+H

TOLLERANZA SULLE PRESTAZIONI INDICATE ± 3%
IN RAGIONE DELL'ALLESTIMENTO E DEGLI ACCESSORI

THE WORKING DIAGRAMS CAN VARY BY ±3% DEPENDING
ON THE TYPE OF INSTALLATION AND ACCESSORIES

I dati e le dimensioni sono forniti a titolo indicativo e non impegnativo.

Data and descriptions are approximate and not binding.

Toutes les données et descriptions sont fournies à titre indicatif, sans engagement.

Angaben und Beschreibungen sind nicht verbindlich.

CODICE **N015.0894**

DATA 10/04/2018

MOD. A

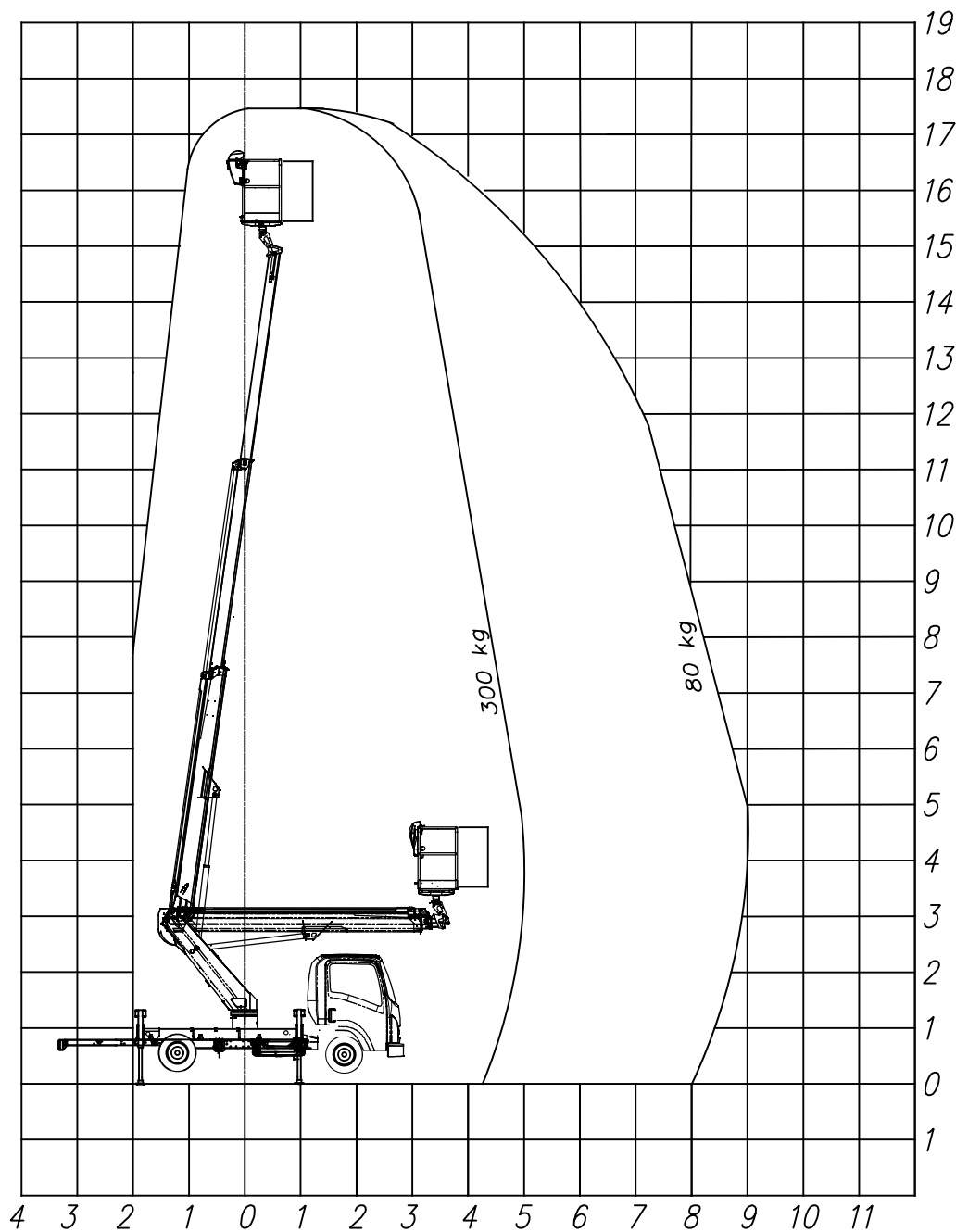

CARATTERISTICHE TECNICHE – TECHNICAL SPECIFICATIONS



ALTEZZA MAX DI LAVORO – MAXIMUM WORKING HEIGHT	17.7m
ALTEZZA PIANO DI CALPESTIO – WALKING FLOOR HEIGHT	15.7m
SBRACCIO MAX DI LAVORO	9,0m
PORTATA – MAXIMUM CAPACITY LOAD	300 kg

DIS. L.N. APPROV. B.M.

PIATTAFORMA
AERIAL WORKING
PLATFORM

18 T (H+H)

Ant. Nissan (no zav)

TOLLERANZA SULLE PRESTAZIONI INDICATE ± 3%
IN RAGIONE DELL'ALLESTIMENTO E DEGLI ACCESSORI

THE WORKING DIAGRAMS CAN VARY BY ±3% DEPENDING
ON THE TYPE OF INSTALLATION AND ACCESSORIES

I dati e le dimensioni sono forniti a titolo indicativo e non impegnativo.

Data and descriptions are approximate and not binding.

Toutes les données et descriptions sont fournies à titre indicatif, sans engagement.

Angaben und Beschreibungen sind nicht verbindlich.

CODICE **NO15.0941**

DATA 10/04/2018

MOD. _____

I dati e le dimensioni sono forniti a titolo indicativo e non impegnativo.

Data and descriptions are approximate and not binding.

Toutes les données et descriptions sont fournies à titre indicatif, sans engagement.

Angaben und Beschreibungen sind nicht verbindlich.

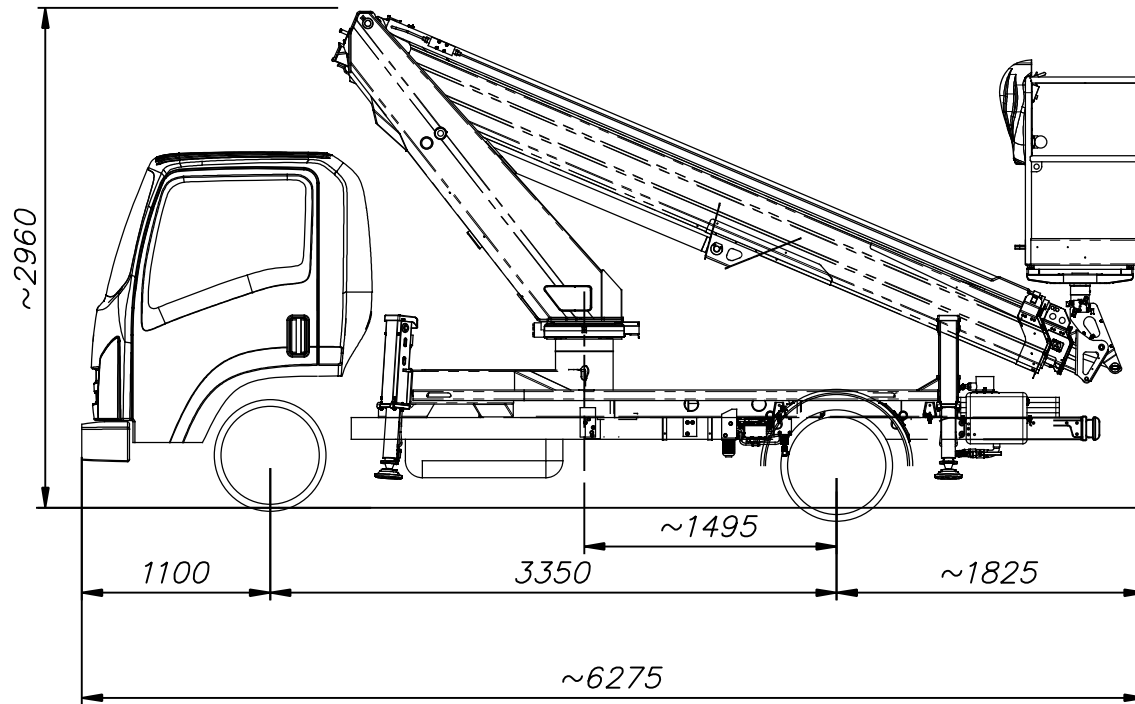
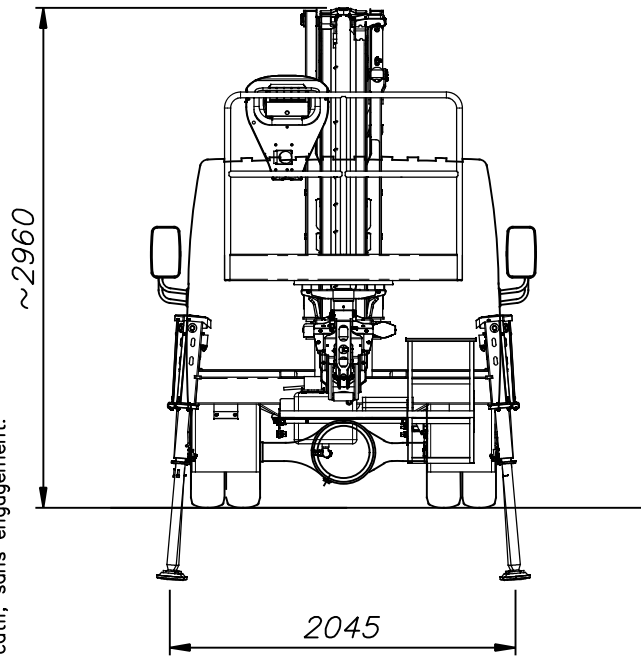

PIATTAFORMA AERIAL WORKING PLATFORM 18T H+H			
VEICOLO TRUCK ISUZU M21 PASSO (WHEELB.) 3350 mm - PTT/GVW 3.5t		DIS. <u> L.N. </u>	APPROV. <u> M.B. </u>
		CODICE NO10.1569	
		DATA <u> 09/11/2018 </u>	MOD. <u> </u>