

# GF28

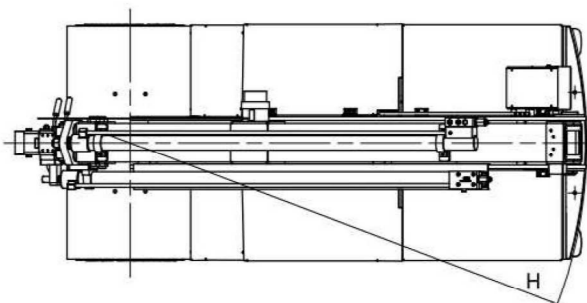
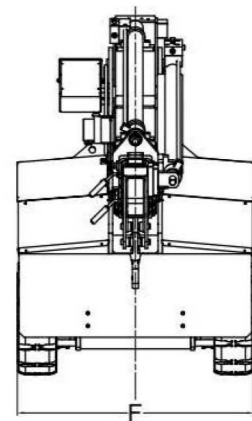
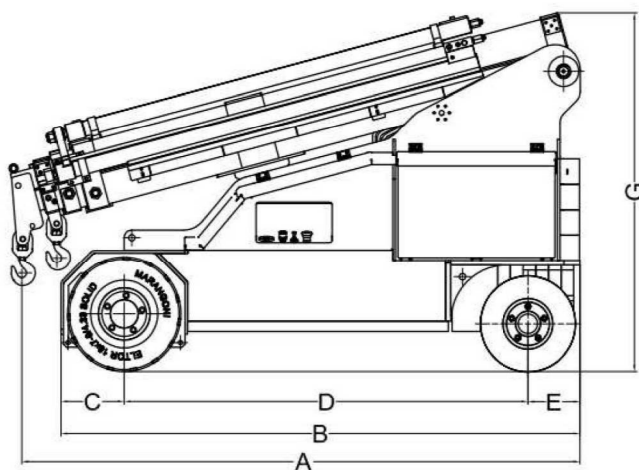
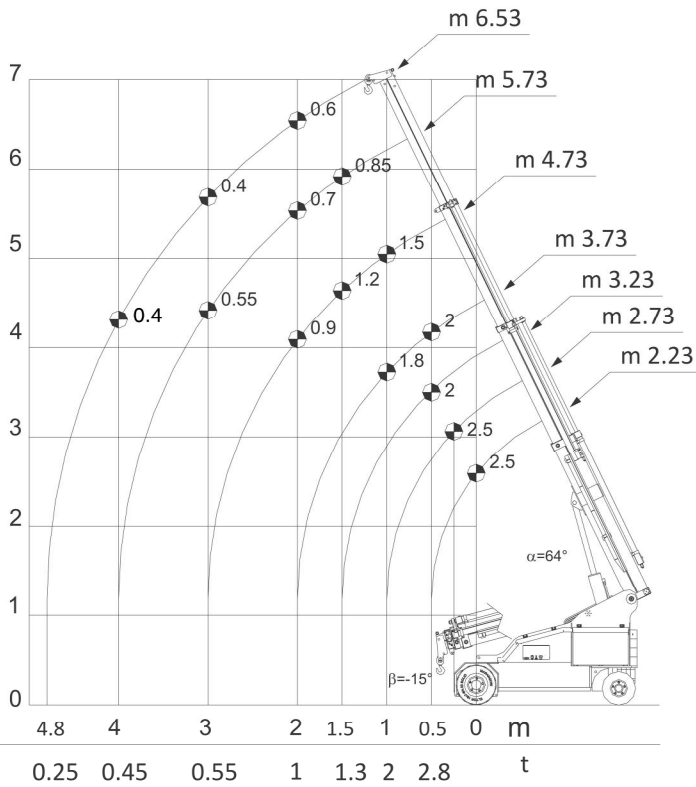

A	mm	2205
B	mm	2130
C	mm	250
D	mm	1595
E	mm	205.5
F	mm	930
G	mm	1410
H	mm	1880

**SPECIFICHE TECNICHE** *Technical specification*

# GF28

<b>Portata massima al gancio principale</b> <i>Main hook max capacity</i>	2800 kg
<b>Raggio di sterzata</b> <i>Steering radius</i>	1880 mm
<b>Peso gru (circa)</b> <i>Weight (about)</i>	3000 kg
<b>Braccio telescopico</b> <i>Telescopic boom</i>	Braccio base, 1 prolunga idraulica, 1 prolunga manuale o idraulica, 1 prolunga manuale. <i>Box boom, 4 sections, 2 section hydraulic, 1 section manual or hydraulic, 1 section manual.</i>
<b>Tipo di sterzata</b> <i>Steering</i>	Idraulica su ponte posteriore <i>Rear hydraulic steering</i>
<b>Gomme</b> <i>Tyres</i>	2 posteriori 15 x 4,5 - 8 e 4 anteriori super elastiche 18 x 7 - 8 <i>2 solid rear 15 x 4.5 - 8. 4 solid front 18 x 7 - 8</i>
<b>Tipo di trazione</b> <i>Drive system</i>	Anteriore bimotores (2 motori) con contro rotazione comandata da controllo elettronico AC (corrente alternata) <i>Front with 2 motors on front axles, with counter rotation operated by high performance AC electronic controllers</i>
<b>Freni</b> <i>Brakes</i>	su asse anteriore (a richiesta su asse posteriore) <i>on front axle (on demand on rear axle)</i>
<b>Versione elettrica</b> <i>Electrical version</i>	Standard AC (corrente alternata) <i>Standard AC</i>
<b>Motori trazione</b> <i>Drive motors</i>	2 kW x 2 (2 kW semiasse ant. dx + 2 kW semiasse ant. sx) <i>2 kW x 2 (2 kW right front axle + 2 kW left front axle)</i>
<b>Batterie</b> <i>Power source</i>	24V 600 Ah
<b>Versione Diesel - idrostatica</b> <i>Diesel-hydrostatic version</i>	Su richiesta <i>On demand</i>
<b>Equipaggiamento di serie</b> <i>Standard equipment</i>	Limitatore di carico elettronico con display, distributore idraulico proporzionale controllato da Joystick, allarme di retromarcia, sedile con sensore uomo presente e cinture di sicurezza, faretto di lavoro. Sistema di auto livellamento idraulico con piastra porta attrezzi, forche (versione MULTIS). <i>Digital safe load indicator with display, joystick-controlled proportional distributor, reversing alarm work light. Auto-levelling hydraulic system with front tool holder plate, forks (MULTIS version) .</i>
<b>Equipaggiamento facoltativo</b> <i>Optional equipment</i>	Gancio supplementare, falconcini, argano, forche, cestello (versione MULTIS), gomme antitraccia, radiocomando, altri su richiesta. Searcher hook, jib, forks, operator platform (MULTIS version), low marking tyres, radio remote control. Other equipment available

Le gru Galizia sono realizzate in conformità alla Direttiva Macchine. La Galizia s.n.c. si riserva il diritto di modificare questi dati senza nessun preavviso.  
Galizia cranes are manufactured in compliance with CE regulation. The company Galizia s.n.c. reserves the right to change the present technical data without previous notice.



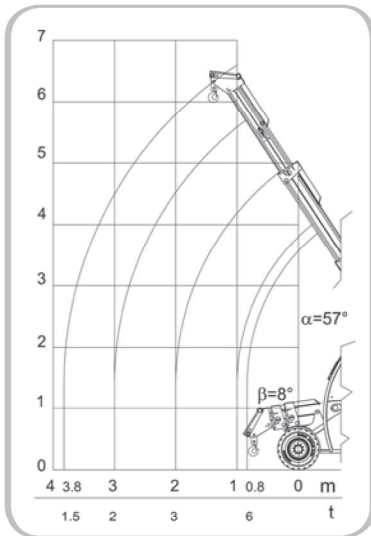

### GANCIO PRINCIPALE Main Hook

Portata massima  
Max capacity 6.000 kg

Altezza massima di lavoro  
Max working height 6 m

### FORCHE Forks

Portata massima  
Max capacity 3.500 kg

Traslatore  
Fork sideshifter Optional

Altezza massima di lavoro  
Max working height 6 m

### PIATTAFORMA AEREA Operator platform

Altezza di lavoro  
Working height 8 m

Altezza piano di calpestio  
Platform height 6 m

Portata massima cestello  
Max operator platform capacity 230 kg

**MULTIS** combines in the same machine the advantages of a pick and carry crane and the practicalness of an industrial multipurpose telehandler.

From its origin as pick and carry crane **MULTIS** derives:

- the power to lift, move and place very heavy loads with no outriggers;
- the main hook applied to the head of the boom, and not on forks or front tool holder plates;
- high precision and gradualness of the movements, guaranteed by up-to-date electronic controls with programmable microprocessors;
- compactness and minimum steering radius;
- front wheel drive twin motor obtained through 2 electrical motors, that can perform counter rotation through an electronic differential gear;
- gradual and exact driving of the boom, obtained through a proportional distributor operated by a joystick, allowing also simultaneous movements;
- safety and reliability;

but offers also multipurpose telehandler characteristics:

- versatility and polyfunctionality, guaranteed by the auto-levelling hydraulic system and the innovative front tool holder plates;
- main tools such as: forks, forks sideshifters, buckets, operator platforms, winch, searcher hooks, jibs etc.

Exclusive characteristics of **MULTIS** are:

- lowered boom, coupled with a front tool holder plate with horizontal cylinder, so to allow
  - wide view from the driving seat;
  - access to the inside of vans or trucks, by both hook and forks;
- support on 4 wheels, while steering like a 3 wheels pick and carry crane, thanks to the coupling of the special rear steering bridge and the front 2 motors drive system;
- 2 AC electric motors for drive and relevant electronic controls;
- 1 AC electric motor for lifting and relevant electronic controls;
- ergonomic and comfortable body, with modern and innovative design;

**MULTIS** is not a simple pick and carry crane, to which some accessories may be added, but a machine really born to be multipurpose.



## SPECIFICHE TECNICHE *Technical specification*

<b>Portata massima al gancio principale</b> <i>Main hook max capacity</i>	6.000 kg
<b>Raggio di sterzata</b> <i>Steering radius</i>	2960 mm
<b>Peso macchina (circa)</b> <i>Weight (about)</i>	6.400 kg
<b>Braccio telescopico</b> <i>Telescopic boom</i>	Completamente idraulico, braccio base, 2 prolunghe. <i>Full hydraulic, 3 sections, box boom</i>
<b>Tipo di sterzata</b> <i>Steering</i>	Idraulica su ponte posteriore <i>Rear hydraulic steering</i>
<b>Gomme</b> <i>Tyres</i>	2 posteriori 23 x 9-10 e 2 anteriori super elastiche 27 x 10-12 <i>2 solid rear 23 x 9-10, 2 solid front 27 x 10-12</i>
<b>Tipo di trazione</b> <i>Drive system</i>	Anteriore bimotore (2 motori) con contro rotazione comandata da controllo elettronico AC (corrente alternata) <i>Front with 2 motors on front axles, with counter rotation operated by high performance AC electronic controllers</i>
<b>Freni</b> <i>Brakes</i>	A disco su asse anteriore (a richiesta su asse posteriore) <i>Disk brakes on front axle (on demand on rear axle)</i>
<b>Versione elettrica</b> <i>Electrical version</i>	Standard AC (corrente alternata) <i>Standard AC</i>
<b>Motori trazione</b> <i>Drive motors</i>	8 kW – AC x 2 (8 kW semiasse ant. dx + 8 kW semiasse ant. sx) <i>8 kW x 2 (8 kW right front axle + 8 kW left front axle)</i>
<b>Batterie</b> <i>Power source</i>	48V - 640 Ah
<b>Versione Diesel - idrostatica</b> <i>Diesel-hydrostatic version</i>	Su richiesta <i>On demand</i>
<b>Equipaggiamento di serie</b> <i>Standard equipment</i>	Limitatore di carico elettronico con display, distributore idraulico proporzionale controllato da Joystick, allarme di retromarcia, sedile con sensore uomo presente e cinture di sicurezza, faretto di lavoro. Sistema di auto livellamento idraulico con piastra porta attrezzi, forche. <i>Digital safe load indicator with display, joystick-controlled proportional distributor, reversing alarm, seat sensor and seatbelt, work light. Auto-levelling hydraulic system with front tool holder plate, forks.</i>
<b>Equipaggiamento facoltativo</b> <i>Optional equipment</i>	Gancio supplementare, falconcini, cestello porta persone, benne, argano idraulico, traslatore per forche, gomme antitraccia, radio comando, altri su richiesta. <i>Searcher hook, jib, operator platform, buckets, full winch system, forks sidershifters, low marking tyres, radio remote control.</i> <i>Other equipment available on demand.</i>

Le gru Galizia sono realizzate in conformità alla Direttiva Macchine. La Galizia s.n.c. si riserva il diritto di modificare questi dati senza nessun preavviso.  
Galizia cranes are manufactured in compliance with CE regulation. The company Galizia s.n.c. reserves the right to change the present technical data without previous notice.

